

Hot Water Economy

CONDENSATE REMOVAL PUMP

Built of heat resistant cyclopy, this economy pump is designed to handle high water temperatures.



900L/h max. flow



6m max. rec. head
(flow rate 180L/h)

KEY FEATURES

- High performance
- Handles 100°C water
- 2 inlets

SUITABILITY

- Up to 1200kW / 4m Btu/h
- Humidifiers; Boilers; Refrigeration; Air handling units (AHUs)

✓ Perfect for... Hot water temperatures

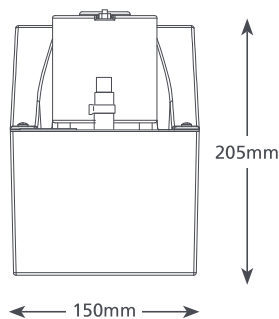
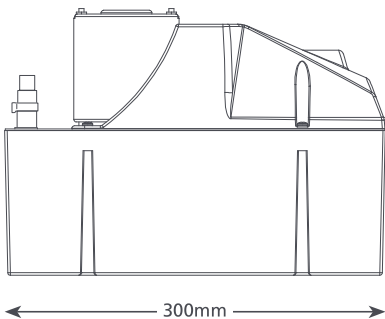

HOT WATER ECONOMY @ 230 VAC 50Hz

Max. flow	900L/h @ 0m head
Max. rec. head	6m
Tank capacity	4L
dB(A) @ 1m	60
Power supply	230 VAC, 1.5A, 50Hz
Rated	Non continuous
Class	I appliance
Max. unit output	1200kW / 4m Btu/h
Max. water temp	100°C / 212°F
Inlet/outlet size	x2 40mm in, 10mm out
IP Protection	IP20
Safety switch	3.0A Normally closed
Thermal protection	✓
Fully potted	n/a
Self priming	n/a

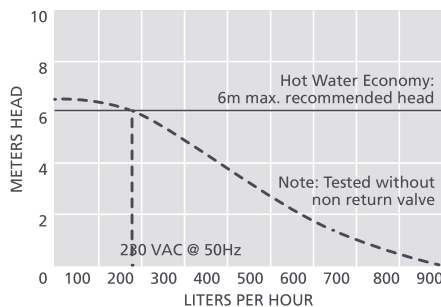

SUGGESTED XTRA ACCESSORIES

Description	Part No.
Tank pump connector 16mm–21mm	FP2011
Tube To Soil Stack Adaptor	FP2038
Vinyl Tube Braided 3/8" (10mm)	AX5111



For more installation accessories take a look at our Aspen Xtra range

HOT WATER ECONOMY OPTIONS

Hot Water Economy	FP2092/2
-------------------	----------

IN THE BOX

- Hot Water Economy Pump • 2m power cable
- Install manual

Download manual at aspenspumps.com